

PLiFi : Analog Amplify and Forward Relaying in Cascaded PLC-LiFi Networks

Anatolij Zubow, Agon Memedi and Falko Dressler
School of Electrical Engineering and Computer Science, TU Berlin, Germany
{zubow,memedi,dressler}@tkn.tu-berlin.de

Abstract—LiFi has become an interesting and now more mature WiFi complement. To overcome the coverage limitations of LiFi and to create robustness against signal blockage, we use analog relays that cooperate with each other in both transmissions and signal reception. We present an ultra low-cost cascaded PLC-LiFi communication system comprising Power-Line Communication (PLC) for backhauling and Light Fidelity (LiFi) for wireless access. The interworking between the two technologies is achieved through low-complexity analog Amplify-and-Forward Relaying (AFR), i.e., the luminaries act as simple media converter. Results reveal the impact of amplification of AFR on the SNR as well as the relationship between the PLC and the optical wireless link length. Moreover, even so the gain from cooperative communication is substantial it is limited due to noise propagation in AFR.

I. INTRODUCTION

Widespread wireless access is crucial for the optimal operation of next-generation services across a range of environments, serving mobile and stationary devices. Industries like manufacturing and healthcare heavily depend on uninterrupted high-speed wireless communication to enable innovative applications. However, achieving such ubiquity is a complex endeavor that demands extensive modifications to the existing networking infrastructure or even the deployment of entirely new infrastructure. This process incurs additional costs and can be impeded by technical limitations, including adherence to Electromagnetic Compatibility (EMC) requirements in sensitive environments such as healthcare and manufacturing.

Our proposal centers around an innovative indoor communication architecture that combines low cost with high performance and wide coverage. We achieve cost-effectiveness through three key approaches. Firstly, we utilize broadband Power-Line Communication (PLC) technology for backhauling, which takes advantage of existing infrastructure (power-lines) and offers easy installation through plug-and-play (PnP) functionality. Secondly, we leverage Light Fidelity (LiFi) for access, utilizing the license-free optical spectrum to provide efficient and affordable connectivity while being robust against jamming. Thirdly, we implement a low-complexity and cost-effective analog Amplify-and-Forward Relaying (AFR) technique for seamless media conversion from power-line to optical transmission. To ensure high performance, we incorporate two key elements. Firstly, we rely on modern communication standards such as ITU-T G.hn, which features flexible Orthogonal Frequency-Division

Multiplexing (OFDM) and adaptive bit-loading techniques. This enables optimized data transmission based on varying channel conditions. Secondly, we employ Cooperative Transmission and Joint Reception by multiple luminaries, also known as Cooperative Multi-Point (CoMP). This approach enhances resilience and helps to mitigate signal blockage issues commonly encountered in optical access scenarios. By combining these elements, our proposed architecture offers a cost-effective solution with widespread coverage, while maintaining high performance capabilities that meet the demands of modern communication requirements.

Our main contributions can be summarized as follows:

- We present PLiFi, a low-cost cell-free (cooperative) indoor communication system,
- We study the most relevant factors influencing its performance.

II. RELATED WORK

The idea of reusing existing infrastructure and/or combination of different technologies to improve communication performance and service quality has been explored in different ways in the literature. In [1], [2], we presented a hybrid access technology composed of RF and LiFi. This technology aggregates the two media, RF and optical, on the physical layer by utilizing the Multiple-Input Multiple-Output (MIMO) capabilities of IEEE 802.11-compliant commodity WiFi hardware. Also, in [3], we presented a concept for networked optical wireless communications to meet the requirements of industrial wireless applications. The key component is the application of distributed multi-user MIMO in the optical access.

Initial ideas about the use of the existing power-line wiring as a backhaul for Visible Light Communication (VLC) have been introduced in [4], [5]. A comprehensive review of integrated and cascaded PLC-LiFi systems with focus on PHY/MAC layer aspects is given by Vappangi [6]. In [4] and [5], Komine et al. present hybrid PLC and VLC networks that are directly integrated (without relaying in between). As such, the signal passing through the PLC network is not demodulated prior to transmission by the LED luminaries.

Other approaches in the literature use relay-assisted techniques for coupling the PLC and VLC networks. For instance, Song et al. [7] use AFR technique for integrating the two networks. In this scheme, the signal in the power-line is

amplified and forwarded to the LEDs without decoding and all the LED luminaries connected to the power adapter share the same PLC modem, therefore transmit the same signal. This creates a homogeneous single frequency network, that mitigates frequent handovers for mobile users moving between service areas of different luminaries, however it can result in interference on overlapping cell borders. This can be addressed using Orthogonal Frequency-Division Multiple Access (OFDMA). To that end, Hao et al. [8] leverage the PLC modem not only as a data source, but also as a centralized controller that coordinates cooperation between multiple LED luminaries for downlink (DL) VLC transmissions. Using Spatial Optical OFDM (SO-OFDM), each LED luminary emits a subset of data symbols from the received PLC OFDM signal, therefore overcoming interference between neighboring cells.

In [9], Jani et al. present a comprehensive performance analysis for a relay-assisted PLC-VLC network that is coupled using Decode-and-Forward Relaying (DFR) technique. The authors follow an analytical approach which uses statistical channel modeling for both PLC and VLC links, and account for the impact of user mobility on the VLC link. The proposed approach allows system analysis for various indoor scenarios and system parameters.

III. BACKGROUND

A. Power-Line Communication (PLC)

The significant advantage of PLC lies in the widespread availability of electrical infrastructure. The existing PLC technologies can be grouped into ultra narrowband (UNB), narrowband (NB), and broadband (BB) [10]. BB-PLC technologies operate in the 1.8–250 MHz bands and there are a variety of standards like TIA-1113 (HomePlug), IEEE 1901 [11] and ITU-T G.hn (G.9960-G.9964).

A widely adopted technology for BB-PLC is the ITU-T G.hn family of standards [12]. In G.hn, the data link layer is defined in ITU-T G.9961,¹ while the physical layer (PHY) is defined in G.9960.² G.9960 specifies a highly flexible physical layer (PHY) based on MIMO-OFDM with several key techniques. First, adaptive bit loading per OFDM subcarrier is employed. This means that the modulation per subcarrier is selected based on the Signal-to-Noise Ratio (SNR) at the corresponding frequency for each endpoint. The loading is adapted constantly, allowing to react to changing channels and optimize the transmission in real-time. This is a very important feature as the BB-PLC channel poses considerable challenges due to its harsh and noisy nature, i.e., it is frequency-selective, time-varying, and impaired by colored background and impulse noise [13]. Second, a modern Forward Error Correction (FEC) scheme, based on Quasi-Cyclic Low-Density Parity-Check Block Codes (QC-LDPC-BC) is employed. Different code rates ranging from 1/2 to 20/21 are supported, allowing fine-granular selection of the rate. Third, adaptive subcarrier spacing is employed to

optimize transmission on various media such as power-lines, coaxial cables, and phone lines. Fourth, G.hn utilizes efficient selective Automatic Repeat Request (ARQ) with block acknowledgments. This approach ensures that only corrupted frames are retransmitted, minimizing unnecessary retransmissions and enhancing overall efficiency. Finally, G.hn allows to operate at (non-continuous) bandwidths from 25 MHz to 200 MHz by masking, i.e., not using, certain subcarriers.

The G.hn MAC provides flexibility and is designed with a master/slave architecture that enables synchronized media access. It offers guaranteed reservation for applications that require quality of service (QoS). There are two options available: contention-based access and contention-free access. The synchronized access occurs within a specific time period known as a MAC cycle. In each MAC cycle, the domain master broadcasts a media access plan (MAP) message to inform the nodes about their allocation for the next MAC cycle. Using the MAP, the domain master divides the MAC cycle into multiple Transmission Opportunities (TXOPs). There are two types of TXOPs available:

- 1) Contention-free TXOP: This type of TXOP enables Time-Division Multiple Access (TDMA) with exclusive channel access for individual nodes.
- 2) Shared TXOP: This type of TXOP allows a group of nodes to share access to the channel using Carrier-Sense Multiple Access (CSMA) mechanisms.

B. Light Fidelity (LiFi)

Optical wireless communication (OWC) serves as an attractive alternative to utilizing radio frequencies for wireless transmission as it offers an unregulated very wide spectrum of hundreds of THz. It possesses unique propagation characteristics, including high directivity, the ability to completely contain signals within walls, and predominant transmission occurring along the Line of Sight (LOS) path [3]. Moreover, inexpensive Light-Emitting Diodes (LEDs) are already installed for lighting and this infrastructure can be easily reused for the purpose of communication. LiFi targets the use of OWC for indoor communication. A key objective is to reuse existing infrastructure by integrating LiFi transceivers into luminaires. In order to overcome the small coverage of LiFi cells a cellular-like ultra-high data density deployment is envisioned. Therefore, LiFi integrates seamless mobility support. There are several standardization efforts around LiFi, like the recently approved IEEE P802.11bb standard, which specifies transparent operation of the existing OFDM-based radio PHYs via LiFi. Therefore, the optical wireless channel becomes yet another media for 802.11 in addition to RF. Experiments with real prototypes have confirmed the feasibility of such an approach [14], [15].

IV. PLiFi ARCHITECTURE

With PLiFi we propose a communication architecture based on two technologies: PLC and LiFi. The end-devices

¹<https://www.itu.int/rec/T-REC-G.9961>

²<https://www.itu.int/rec/T-REC-G.9960>

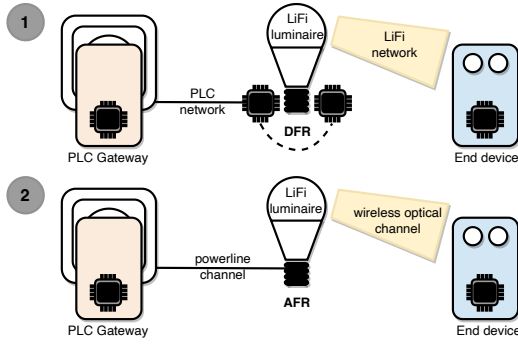

Fig. 1: The two types of relaying: 1) Decode-and-Forward Relaying (DFR), 2) Amplify-and-Forward Relaying (AFR).

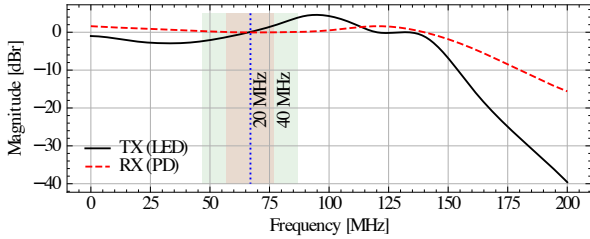

Fig. 2: The frequency response of the broadband LiFi front-end developed by Fraunhofer HHI in Berlin.

are mobile and are connected via short-range free-space optical communication (LiFi) to the infrastructure via Amplify-and-Forward (AF) relays (Fig. 1). The AF relays act as simple media converter and translate the signal from the optical to the power-line channel used in the backhaul. Moreover, signal amplification is performed inside the AFR for both DL and uplink (UL) communication which is needed in order to compensate for the signal attenuation on the channel, i.e., loss in power-line and optical channel for DL and UL, respectively. In the backhaul the different AF nodes are interconnected via the shared power-line media to the gateway node which provides connectivity to external networks, e.g., the Internet. Moreover, multiple AFR nodes can cooperate with each other to jointly transmit the same signal in the DL while jointly receive the UL signal. This is a form of a CoMP system. The usage of CoMP creates robustness against signal blockage in the optical channel and also enables seamless mobility in the area covered by the cooperating AFR nodes. The solution remains simple and inexpensive as no additional mechanisms for coding/decoding and explicit synchronization are required.

As PLC technology we selected the G.hn standard. Hence, both the PLC gateway and the LiFi end-devices are equipped with G.hn transceivers. As with our analog operation (AFR) we have a single shared collision domain consisting of the power-line and the optical free-space (LiFi) channels, the media conversion and amplification performed by the AFR nodes remains transparent to both the GW and the LiFi end-devices (Fig. 1). Moreover, the G.hn transceiver in the LiFi end-devices believes to be directly connected to the power-line channel. Hence the two G.hn chips of the two ends of a

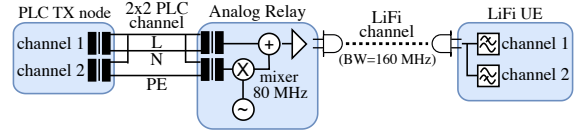

Fig. 3: Amplify-and-Forward Relaying with media conversion from power-line to/from optical channel.

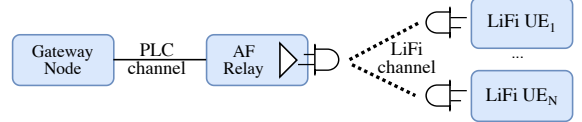

Fig. 4: Basic version of PLiFi.

link will estimate the effective end-to-end channel and will be able to compensate for any additional distortions introduced on the optical link and the optical front-end (OFE) hardware (Fig. 2) using the flexibility of G.hn like bit-loading.

The main advantage of AFR over the classical DFR is its ultra-low cost, i.e., a few analog components vs. two full PLC transceivers (Fig. 1).

A. Amplify-and-Forward Relaying

Fig. 3 gives more details on the envisioned communication system with analog AFR between power-line and optical channels (media). As both the gateway node and the end-devices are equipped with a single PLC (G.hn) transceiver, the AFR operation with its media conversion must be transparent. However, as PLC based on G.hn supports MIMO (spatial multiplexing) the signals from the two power-line channels need to be decoupled inside the AFR. This is challenging as our LiFi channel does not support spatial multiplexing, i.e., it is a simple Single-Input Single-Output (SISO) system. We solve this problem by multiplexing the two power-line MIMO streams onto two optical channels separated in the frequency domain, i.e., FDM with stream 2 is shifted by 80 MHz and added to stream 1 before modulation in OFE using IM/DD. On the receiver side (LiFi UE) the two streams are reconstructed by proper filtering the baseband signal from the OFE before passing to the PLC transceiver for decoding. From the perspective of both the gateway and the end-devices the AFR operation, i.e., signal amplification and media conversion, is fully transparent, i.e., both assume to be connected directly by PLC.

B. Basic PLiFi

Our basic version is a system consisting of three components, namely gateway node (GW), single AFR, and $1-N$ LiFi end-devices. The transmission in the downlink (DL) towards some end-device can be described as follows:

$$y_{DL}[m] = h_{LiFi}[m] \sqrt{\alpha_{DL}} (h_{PLC}[m]x[m] + n_{PLC}[m]) + n_{LiFi}[m] \quad (1)$$

where h_{PLC} and h_{LiFi} are the fixed complex channel gains of the PLC and LiFi channel, respectively; α is the power

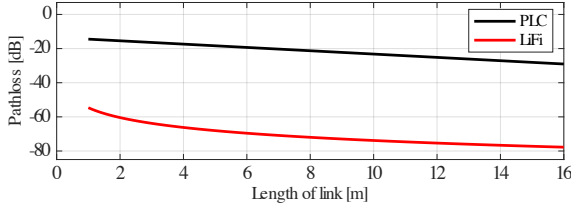

Fig. 5: Average pathloss over distance for PLC and LiFi.

amplification used by the AFR and $n_{PLC}[m]$ and $n_{LiFi}[m]$ are the additive Gaussian noise.

Effectively the DL TX power at the AFR becomes:

$$P_{AFR}^{DL} = \alpha_{DL} |h_{PLC}|^2 P_{PLC}^{TX} \quad (2)$$

Hence in order to compensate for the loss in the PLC channel we need to set $\alpha = |h_{PLC}|^{-2}$.

The SNR of the OFDM subcarrier i is calculated as follows:

$$SNR_s^{DL} = \frac{\alpha_{DL} P_{PLC}^{TX} |h_{LiFi,s} h_{PLC,s}|^2}{|h_{LiFi,s}|^2 \alpha_{DL} \sigma_{PLC}^2 + \sigma_{LiFi}^2} \quad (3)$$

Note that, due to the analog AFR the noise from the PLC channel is propagated by the AFR to the LiFi channel and hence to the LiFi end-devices. Finally, all AFR nodes who transmit a different signal contribute to interference.

The uplink (UL) can be defined in the same way:

$$y_{UL}[m] = h_{PLC}[m] \sqrt{\alpha_{UL}} (h_{LiFi}[m]x[m] + n_{LiFi}[m]) + n_{PLC}[m] \quad (4)$$

Effectively the UL TX power at the AFR becomes:

$$P_{AFR}^{UL} = \alpha_{UL} |h_{LiFi}|^2 P_{LiFi}^{TX} \quad (5)$$

Note, that in contrast to DL the UL requires a larger amplification, i.e., $\alpha_{UL} > \alpha_{DL}$. This is because signal attenuation over distance in the LiFi channel is much larger than in PLC channel, i.e., around 50 dB (Fig. 5). At the same time, we must ensure that the signal injected by the AFR into the PLC does not exceed the maximum allowed transmit power for broadband PLC communication.

Similar to the DL, the per-subcarrier SNR for the UL, SNR_i^{UL} , can be computed.

C. Cooperative PLiFi

One major drawback of basic PLiFi is its poor coverage in the access network within a pico-cell. The pico-cell for a single luminary is only a few meters in size, hence the LiFi coverage is confined. Moreover, in such a setup there is only a single AF relay. We address this problem benefiting from cooperative AFR. The key idea is to have multiple AFR nodes which cooperate with each other to jointly transmit the same signal in the DL while jointly receiving the UL signal (Fig. 6). Hence, a broader coverage can be established even in large conference rooms by installing multiple AFR nodes. Furthermore, this increases the robustness of the LiFi access network against signal blockage, as the probability that the LOS path from a given end-device towards all AFR is blocked

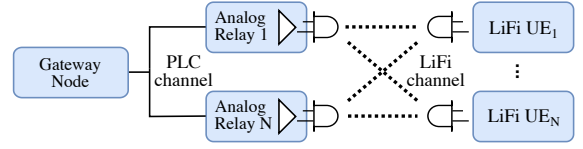

Fig. 6: Cooperative version of PLiFi with multiple AFR nodes collaborate with each other in DL (joint transmission) and UL (joint reception).

at the same time is small, given that the set of cooperating AFR is sufficiently large.

From the perspective of the DL we have a distributed Multiple-Input Single-Output (MISO) system with joint transmission from multiple AFR nodes towards a single end-device:

$$y_{DL}^{coop}[m] = \sum_{i \in AFR} h_{LiFi}^i[m] \sqrt{\alpha_{DL}^i} (h_{PLC}^i[m]x[m] + n_{PLC}[m]) + n_{LiFi}[m] \quad (6)$$

where AFR is the set of AF relays participating in the DL transmission. Here, the transmission from the gateway node is amplified and relayed by all cooperating nodes from AFR towards a single LiFi UE. Explicit synchronization among the AFR nodes is not needed as it happens implicitly over the PLC channel, i.e., the signal arrives approx at the same time at each AFR, which then forward it without delay. Even different signal propagation times due to different PLC/LiFi link length do not result in Intersymbol Interference (ISI). This is because the OFDM cyclic prefix used by G.hn-PLC, $1.28 \mu s$, is sufficiently large to absorb the maximum delay spread of up to 1 km in the channel which is dominated by the cable length in the PLC channel. Note, the impact from LiFi can be ignored due to its very small coverage, resulting in very small delay spreads. Hence, in the cooperative approach we are able to obtain a diversity gain in both PLC and LiFi channel.

The signals sent out by the different AFR nodes are identical which is different from the DF approach, where space-time or space-frequency codes can be used. However, as multiple AFR nodes are able to relay the signal with full power we obtain a power gain in the DL. Moreover, the amplification gain used by each AFR could be different considering the individual channel gains from both PLC and LiFi.

The SNR of the OFDM subcarrier i is calculated for our cooperative approach as follows:

$$SNR_s^{coop,DL} = \frac{\alpha_{DL} P_{PLC}^{TX} \left| \sum_{i \in AFR} h_{LiFi,s}^i h_{PLC,s}^i \right|^2}{\sigma_{LiFi}^2 + \left| \sum_{i \in AFR} h_{LiFi,s}^i \sqrt{\alpha_{DL}^i} \sigma_{PLC} \right|^2} \quad (7)$$

whereas the UL is given as:

$$y_{UL}^{coop}[m] = \sum_{i \in AFR} h_{PLC}^i[m] \sqrt{\alpha_{UL}^i} (h_{LiFi}^i[m]x[m] + n_{LiFi}[m]) + n_{PLC}[m] \quad (8)$$

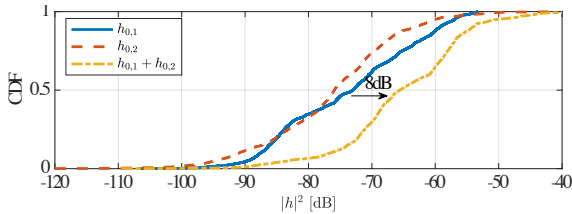

Fig. 7: Channel gain from cooperative transmission for two arbitrary selected channels (residential apartment).

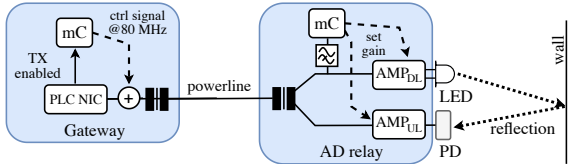

Fig. 8: Solution to the feedback loop problem.

Note, that with the joint reception used in UL we also obtain a diversity gain but no power gain.

As an example, Fig. 7 shows the PLC channel gain (squared magnitude) per OFDM subcarrier towards two arbitrary selected nodes, $h_{0,1}$ and $h_{0,2}$ captured in a real residential environment using a network analyzer (Agilent). In addition, we computed the channel gain of a joint transmission over both nodes, $h_{0,1} + h_{0,2}$. From the CDF plot we see the large improvement in terms of channel gain even with just two cooperating nodes.

D. Feedback Loop

With AFR, there is a risk of creating a feedback loop when the signal transmitted by the LED is reflected from an obstacle (e.g., a wall) and immediately received by the PD of the AFR-OFE and injected into PLC after amplification. This signal is again amplified and radiated by the LED. Fig. 8 shows our solution. The key idea here is to switch off the amplification of the UL signal received by the PD for the duration of the DL transmission. Therefore, we exploit the fact that modern PLC chips like MaxLinear G.hn Wave-2 have a TX enabled PIN which is high for the duration of a packet transmission. This signal is used by a micro controller (mC) to create an analog narrowband control (ON/OFF) signal centered at 80 MHz

TABLE I: Parameters used in the evaluation.

Parameter	Value
PLC	G.hn
Total bandwidth B	100 MHz
OFDM	SC spacing 24.41 kHz (CP=1.28 μ)
Code rate / spatial streams	0.9 / 1-2
TX PSD	2-30 MHz: -55 dBm/Hz 30-100 MHz: -85 dBm/Hz
Large-scale pathloss model	indoor broadband PLC [16]
Noise model	thermal (NF=12 dB)
LiFi	
Broadband OFE	200 MHz
Modulation	IM/DD
Large-scale pathloss model	infrared optical inside aircraft [17]
Noise model	thermal (NF=8 dB)

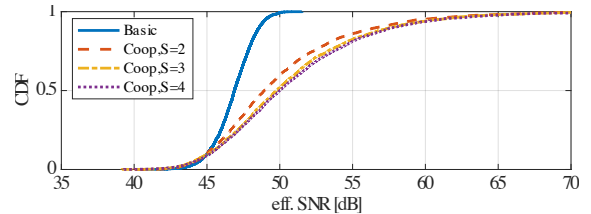

Fig. 9: DL SNR for different AFR sizes S .

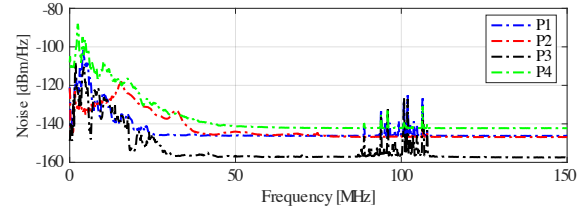

Fig. 10: Measured noise in PLC in typical residential area.

which is transmitted over the power-line channel together with the actual data signal (2-79MHz). Inside the AFR this signal is received by the mC which turns off the UL amplification for the duration of the DL transmission. Note that, such control signal could also be used to perform fine-grained gain control for UL and DL for each AFR node.

V. EVALUATION AND DISCUSSION

In this section we present the results from our evaluation. The most important parameters are summarized in Table I.

As shown in Fig. 7, there is a channel gain when using cooperative PLiFi. However, at the same time the noise floor is amplified because of the AFR operation. Therefore, we analyzed the impact of the number of cooperating AF nodes S on the SNR. In our modeling the PLC and LiFi channels were modeled as iid complex Gaussian with 10 and 2 channel taps, respectively. Note, that the large-scale pathloss was the same for each PLC and LiFi link, respectively. The LiFi link was fixed to 4 m resulting in an end-to-end wide-band SNR at 47 dB. The amplification was fixed to $\alpha = 50$ dB.

Fig. 9 shows the distribution of effective SNR, i.e., average over the subcarriers from 2-30 MHz, over different channel realizations. We see a clear gain of having two cooperative AF nodes $S = 2$, as compared to the basic version. However, a further increase in S only leads to marginal increase in SNR. The reason is as follows: Even though the received power increases with S , the noise floor increases as well. This is because of the noise propagation which is inherent to the analog AFR. Hence for $S > 3$ there is not much gain in the SNR. This is not a problem because our primary goal was to increase the robustness to link blockage due to shadowing.

Single Collision Domain With AFR we create a single shared collision domain comprising the power-line and the optical wireless (LiFi) channels. As in G.hn the channel access is coordinated by the domain master (cf. §III-A), which is the PLC gateway in our case, the media access is extended on the optical channel. Hence, both multiple access and duplexing are resolved by the master. Moreover,

for MAC both options are feasible: TDMA and CSMA. For CSMA, the LiFi end-terminals need to perform carrier sensing before transmitting in the UL. Co-existence of multiple PLiFi networks is achieved using co-existence capabilities of G.hn.

Issue with Noise With AFR the signal is not reconstructed and therefore the noise is propagated from power-line to the optical channel and vice versa. Especially, as the noise in power-line can be very high due to missing RF shielding as our own measurements have confirmed (Fig. 10). Therefore, reduction measures must be taken, i.e., by avoiding connecting unnecessary electrical devices.

Media Conversion The G.hn profile for PLC is used for the transmission over the optical channel as well. This reduces the data rate by $\approx 8\%$ as subcarriers which are available for transmission over the optical wireless channel cannot be used due to required puncturing in the power-line. The digital approach would not have this disadvantage. Moreover, no rate conversion is possible with our approach.

Service Quality The usage of OWC for access has several advantages like the possibility of guaranteed delivery at low latency (deterministic channel access) as the amount of external factors which cannot be controlled are smaller than in RF. Optical communication in general is inherently robust against external jamming (even a thin wall is sufficient as protection). Absence of multipath fading makes link performance predictable and link blockage due to shadowing can be easily compensated using CoMP which is easy to realize as the AFR nodes are implicitly synchronized in both DL and UL. PLiFi is suitable for time-sensitive applications as the AFR operation does not introduce any additional processing delay as the signal is only filtered and amplified.

Power-line as Limiting Factor The capacity of PLC is limited due to reasons like the shared medium, unshielded cables, large impact from external interference, strong multipath. There are possibilities for improvement. The power-lines used for backhauling can be replaced by other media like coaxial cables. This is feasible as G.hn is also defined for transmission over coaxial cables offering superior performance due to better RF shielding and better propagation characteristics. Such a change is easy to make as only the G.hn profile need to be changed from PL to coax. However, it would result in significant installation costs.

VI. CONCLUSIONS

We presented PLiFi a hybrid communication system which uses optical wireless communication for providing access while PLC technology is used for backhauling. By relying on simple analog amplify-and-forwarding, where the access points act as simple media converter, our solution is of low-complexity and inexpensive. To overcome the coverage limitations of optical communication and to enable robustness against signal blockage due to shadowing, multiple analog relays can cooperate with each other to enable simultaneous transmissions and joint signal reception. As future work, we plan to implement a full prototype of PLiFi and study its performance under real world conditions.

ACKNOWLEDGEMENTS

This work was supported by the Federal Ministry of Education and Research (BMBF, Germany) within the 6G Research and Innovation Cluster 6G-RIC under Grant 16KISK020K as well as by the Federal Ministry for Economics and Climate Action (BMWK) under grant 01MT22001G.

REFERENCES

- [1] A. Zubow, P. Gawłowicz, C. Brunn, K. L. Bober, V. Jungnickel, K. Habel, and F. Dressler, "Hybrid-Fidelity: Utilizing IEEE 802.11 MIMO for Practical Aggregation of LiFi and WiFi," *IEEE Transactions on Mobile Computing*, vol. 22, no. 8, pp. 4682–4697, Aug. 2023.
- [2] A. Zubow, P. Gawłowicz, K. L. Bober, V. Jungnickel, K. Habel, and F. Dressler, "Hy-Fi: Aggregation of LiFi and WiFi using MIMO in IEEE 802.11," in *IEEE WoWMoM 2021. Virtual Conference: IEEE*, Jun. 2021, pp. 100–108.
- [3] K. L. Bober, S. M. Mana, M. Hinrichs, S. M. Kouhni, C. Kottke, D. Schulz, C. Schmidt, R. Freund, and V. Jungnickel, "Distributed Multiuser MIMO for LiFi in Industrial Wireless Applications," *Journal of Lightwave Technology*, vol. 39, no. 11, pp. 3420–3433, Jun. 2021.
- [4] T. Komine and M. Nakagawa, "Integrated system of white LED visible-light communication and power-line communication," in *IEEE PIMRC 2002*. Lisbon, Portugal: IEEE, Sep. 2002.
- [5] —, "Integrated system of white LED visible-light communication and power-line communication," *IEEE Transactions on Consumer Electronics*, vol. 49, no. 1, pp. 71–79, Feb. 2003.
- [6] S. Vappangi and V. Mani, "A survey on the integration of visible light communication with power line communication: Conception, applications and research challenges," *Elsevier Optik*, vol. 266, p. 169582, Sep. 2022.
- [7] J. Song, W. Ding, F. Yang, H. Yang, B. Yu, and H. Zhang, "An Indoor Broadband Broadcasting System Based on PLC and VLC," *IEEE Transactions on Broadcasting*, vol. 61, no. 2, pp. 299–308, 2015.
- [8] H. Ma, L. Lampe, and S. Hranilovic, "Hybrid Visible Light and Power Line Communication for Indoor Multiuser Downlink," *Journal of Optical Communications and Networking*, vol. 9, no. 8, p. 635, 2017.
- [9] M. Jani, P. Garg, and A. Gupta, "On the Performance of a Cooperative PLC-VLC Indoor Broadcasting System Consisting of Mobile User Nodes for IoT Networks," *IEEE Transactions on Broadcasting*, vol. 67, no. 1, pp. 289–298, Mar. 2021.
- [10] L. T. Berger, A. Schwager, S. Galli, P. Pagani, D. M. Schneider, and H. Lioe, "Current Power Line Communication Systems: A Survey," in *MIMO Power Line Communications*, A. Schwager, P. Pagani, and D. M. Schneider, Eds. Boca Raton, FL: CRC Press, 2014, pp. 253–269.
- [11] IEEE, "IEEE Standard for Broadband over Power Line Networks: Medium Access Control and Physical Layer Specifications," IEEE, Std 1901-2020, Jan. 2021.
- [12] V. Oksman and S. Galli, "G.hn: The new ITU-T home networking standard," *IEEE Communications Standards Magazine*, vol. 47, no. 10, pp. 138–145, 2009.
- [13] H. C. Ferreira, L. Lampe, J. Newbury, and T. G. Swart, Eds., *Power Line Communications*. Wiley, 2010.
- [14] P. Gawłowicz, E. Alizadeh Jarchlo, and A. Zubow, "WiFi over VLC using COTS Devices," in *IEEE INFOCOM 2020, CNERT Workshop*. Virtual Conference: IEEE, Jul. 2020.
- [15] —, "Bringing MIMO to VLC using COTS WiFi," in *IEEE ICC 2020, OWC Workshop*. Virtual Conference: IEEE, Jun. 2020.
- [16] M. Heggo, X. Zhu, Y. Huang, and S. Sun, "A novel statistical approach of path loss mapping for indoor broadband power line communications," in *IEEE SmartGridComm 2014*. Venice, Italy: IEEE, Nov. 2014.
- [17] S. Dimitrov, R. Mesleh, H. Haas, M. Cappitelli, M. Olbert, and E. Bassow, "Path Loss Simulation of an Infrared Optical Wireless System for Aircrafts," in *IEEE GLOBECOM 2009*. Honolulu, HI: IEEE, Nov. 2009.